



四川航昱微电子科技有限公司  
SICHUAN HANGYU MICROELECTRONICS TECHNOLOGY CO., LTD.

SPECIFICATION FOR APPROVAL

承认书

Spec. No.: HYV6355 Series

Issued Date: 2024-04-24

CUSTOMER:

客户

PART NAME: SMD Plastic Varistors

名称 SMD 塑封压敏电阻器

APPLICATION: Absorb the surge voltage

用途 吸收浪涌电压

PART NO.:

料号 HYV6355 series

UL FILE NO:

UL 证书号

CUSTOMER PART NO.:

客户料号

客户承认 CUSTOMER CONFIRM

承认章	核准	审核	经办人
STAMP	APPROVE	CHECK	SIGNATURE

公司名称: 四川航昱微电子科技有限公司  
SICHUAN HANGYU MICROELECTRONICS TECHNOLOGY CO., LTD.

公司地址: 四川省泸州市江阳区利民路二段9号

电话: 19182727601

网址: <http://www.hywdz.com>

Part No: HYV6355 series	Rev: 0/A (2024-04-24)
-------------------------	-----------------------

1. Appearance 外形尺寸

1-1. Marking 标志	 Logo 公司商标 V6355-471 Product Spec. 产品规格 240602 Batch no. 生产批号
-----------------	--

1-2. Dimensional Drawing (mm) 尺寸

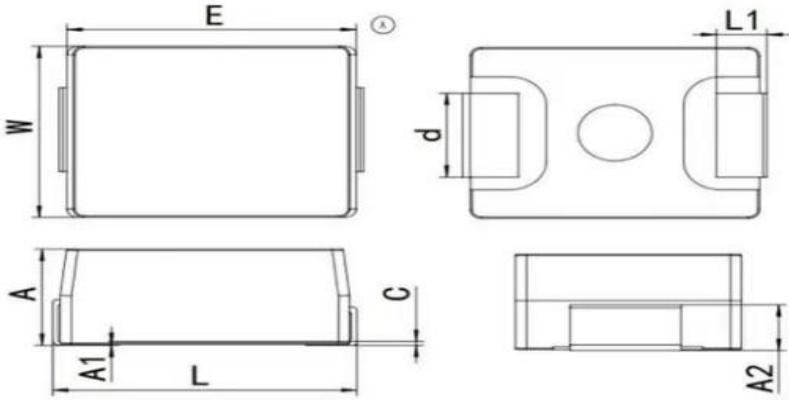

UNIT		E	W	A	L	A1	A2	d	L1	C
mm	max	17.0	15.5	4.5	17.5	0.15	2.6	6.5	5.5	0.25
	min	15.0	13.5	3.9	15.5	0.10	1.8	5.5	4.5	0.15

1-3. Recommended solder pad layout (mm) 焊盘布局 (暂时不明)

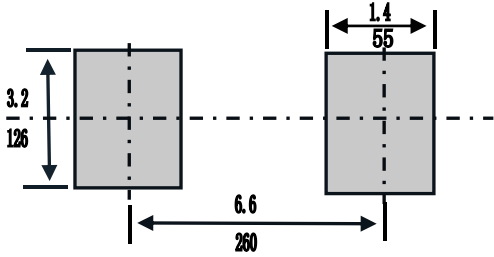

unit:  $\frac{mm}{(mil)}$

2. Part numbering 命名方式

HY	V	6355	471	K	J
Blue Sky Logo	Plastic Varistors	Product Size 产品尺寸 mm	Varistor Voltage 压敏电压 V	Tolerance 压敏电压允差	High flux energy 高通流能量
航昱微 Logo	塑封压敏电阻	16.0*14.0	470	±10%	J-高焦耳 H-高能

Part No: HYV6355 series

Rev: 1/A (2024-04-24)

## 3. Electrical Characteristics 电气参数

(Ta=25℃)

SMD Types 产品型号	Maximum Allowable Voltage 可容许最大电压		Withstanding Surge Current (8/20 μs) 突波电流耐量		Energy 能量 (10/1000μs)	Rated Power 额定功率
	V <sub>ACRMS</sub> [V]	V <sub>DC</sub> [V]	1 time[A]	2 times[A]	(1 time)[J]	[mW]
HYV6355-221KJ	140	180	4500	2500	60	0.6
HYV6355-241KJ	150	200	4500	2500	63	0.6
HYV6355-271KJ	175	225	4500	2500	70	0.6
HYV6355-331KJ	210	275	4500	2500	85	0.6
HYV6355-361KJ	230	300	4500	2500	93	0.6
HYV6355-391KJ	250	320	4500	2500	100	0.6
HYV6355-431KJ	275	350	4500	2500	115	0.6
HYV6355-471KJ	300	385	4500	2500	125	0.6
HYV6355-511KJ	320	415	4500	2500	125	0.6
HYV6355-561KJ	350	455	4500	2500	125	0.6
HYV6355-621KJ	385	505	4500	2500	125	0.6
HYV6355-681KJ	420	560	4500	2500	130	0.6
HYV6355-751KJ	460	615	4500	2500	143	0.6
HYV6355-781KJ	485	640	4500	2500	150	0.6
HYV6355-821KJ	510	670	4500	2500	157	0.6
HYV6355-911KJ	550	745	4500	2500	175	0.6

Part No: HYV6355 series			Rev: 1/A (2024-04-24)			
SMD Types 产品型号	Maximum Allowable Voltage 可容许最大电压		Withstanding Surge Current (8/20 $\mu$ s) 突波电流耐量		Energy 能量 (10/1000 $\mu$ s)	Rated Power 额定功率
	V <sub>ACRMS</sub> [V]	V <sub>DC</sub> [V]	1 time[A]	2 times[A]	(1 time)[J]	[mW]
HYV6355-221KH	140	180	6500	4000	60	0.6
HYV6355-241KH	150	200	6500	4000	63	0.6
HYV6355-271KH	175	225	6500	4000	70	0.6
HYV6355-331KH	210	275	6500	4000	85	0.6
HYV6355-361KH	230	300	6500	4000	93	0.6
HYV6355-391KH	250	320	6500	4000	100	0.6
HYV6355-431KH	275	350	6500	4000	115	0.6
HYV6355-471KH	300	385	6500	4000	125	0.6
HYV6355-511KH	320	415	6500	4000	125	0.6
HYV6355-561KH	350	455	6500	4000	125	0.6
HYV6355-621KH	385	505	6500	4000	125	0.6
HYV6355-681KH	420	560	6500	4000	130	0.6
HYV6355-751KH	460	615	6500	4000	143	0.6
HYV6355-781KH	485	640	6500	4000	150	0.6
HYV6355-821KH	510	670	6500	4000	157	0.6
HYV6355-911KH	550	745	6500	4000	175	0.6

Part No: HYV6355 series

Rev: 1/A (2024-04-24)

## 3. Electrical characteristics 电气参数

(Ta=25°C)

SMD Types 产品型号	Varistor Voltage at 1 mA 压敏电压	Max Clamping Voltage at Class Current 最大抑制电压	Capacitance 电容量
	[V](±10%)	[V]	@1kHz [pF]
HYV6355-221KJ	220	360	1000
HYV6355-241KJ	240	395	900
HYV6355-271KJ	270	455	740
HYV6355-331KJ	330	550	650
HYV6355-361KJ	360	595	560
HYV6355-391KJ	390	650	510
HYV6355-431KJ	430	710	460
HYV6355-471KJ	470	775	430
HYV6355-511KJ	510	845	430
HYV6355-561KJ	560	925	360
HYV6355-621KJ	620	1025	320
HYV6355-681KJ	680	1120	290
HYV6355-751KJ	750	1240	270
HYV6355-781KJ	780	1290	270
HYV6355-821KJ	820	1355	240
HYV6355-911KJ	910	1500	220

Part No: HYV6355 series

Rev: 1/A (2024-04-24)

SMD Types 产品型号	Varistor Voltage at 1 mA 压敏电压	Max Clamping Voltage at Class Current 最大抑制电压	Capacitance 电容量
	[V](±10%)	[V]	@1kHz [pF]
HYV6355-221KH	220	360	1000
HYV6355-241KH	240	395	900
HYV6355-271KH	270	455	740
HYV6355-331KH	330	550	650
HYV6355-361KH	360	595	560
HYV6355-391KH	390	650	510
HYV6355-431KH	430	710	460
HYV6355-471KH	470	775	430
HYV6355-511KH	510	845	430
HYV6355-561KH	560	925	360
HYV6355-621KH	620	1025	320
HYV6355-681KH	680	1120	290
HYV6355-751KH	750	1240	270
HYV6355-781KH	780	1290	270
HYV6355-821KH	820	1355	240
HYV6355-911KH	910	1500	220

Part No: HYV6355 series

Rev: 1/A (2024-04-24)

## 4. Mechanical Characteristics 机械性能

Item 指标项目	Specification 技术要求	Description 说明
Tensile 引出端拉伸强度	The lead wire is not broken and the resistor is not damaged. Pressure sensitive voltage change rate within $\pm 5\%$ . 引线无断裂，电阻器无损伤。压敏电压变化率在 $\pm 5\%$ 以内。	Referring to GBT10193-1997(4.10) , UA1 UUB UC and Ud are quoted in IEC 43-2-21 to carry out the strength test of the leading end. 10 n tensile force . 参照 GBT10193-1997 第 4.10, 引用 IEC 43-2-21 中规定 Ua1、Ub、Uc 和 Ud 进行引出端强度试验。引出端施加10N拉力。
Vibration 振动	No significant mechanical damage. The rate of change of voltage is less than 10% . 无明显机械损伤。压敏电压变化率小于10%。	The test sample should be tested according to the GB 2423.10 Test Fe, the frequency is 10-55 Hz, the displacement amplitude is 0.75 mm, along the test sample x, Y two directions vibration 2Hr. 试验样品应根据GB 2423.10试验Fe进行试验，频率为10-55Hz，位移幅值为0.75mm，沿试验样品X, Y两个方向各振动2Hr。
Solderability 可焊性	About 95 % of the lead end is evenly covered by solder. Not less than 90 % of wetting force. 引线末端约95%被焊锡均匀覆盖。不小于润湿力的90。	Referring to GBT10193-1997(4.11) , IEC 43-2-20 test method is used to insert the varistor (5 + 1) mm / s ~ (20 + 1) mm / s) into the molten solder at the temperature of (235 $\pm$ 0.5) ° C for 5 S. 参照GBT10193-1997第4.11, 引用IEC 43-2-20的试验方法，焊料温度 (235 $\pm$ 0.5) °C，将压敏电阻器以 (5+1) mm/s~ (20+1) mm/s的速度侵入熔融焊料中1.5至规定的深度，并保持5 S。
Welding heat resistance 耐焊接热	No significant mechanical damage. Pressure sensitive voltage change rate within $\pm 5\%$ . 无明显机械损伤。压敏电压变化率在 $\pm 5\%$ 以内。	According to 4.12 of GBT10193-1997 and the test Tb method stipulated in IEC 43-2-20, the pins of the psa were impregnated in a welding groove at (260 $\pm$ 5) ° C for (10+1) s. 参照GBT10193-1997第4.12, 引用IEC 43-2-20规定试验Tb方法，将压敏电阻器的引脚浸渍于 (260 $\pm$ 5) °C 的焊槽中，持续 (10+1) s。

Part No: HYV6355 series

Rev: 1/A (2024-04-30)

## 5. Environmentalb 耐候特性

Characteristicsvv 项目	Test Methods 试验方法	Specifications 性能要求
High Temperature Storage 高温存储	The specimen shall be subjected to $125\pm 2^{\circ}\text{C}$ for 1000 hours in a thermostatic bath without load and then be stored at room temperature and normal humidity for 1 to 2 hours. The change of $V_{1\text{mA}}$ shall be measured.  在 $125\pm 2^{\circ}\text{C}$ 无负荷存放 1000 小时, 其后在室温状态下, 1 到 2 小时以内, 测量 $V_{1\text{mA}}$ 。	$ \Delta V_{1\text{mA}}/V_{1\text{mA}} $ $\leq 10\%$
Humidity Storage 湿热湿热	The specimen shall be subjected to $40\pm 2^{\circ}\text{C}$ , 90~95%RH for 1000hours without load and then stored at room temperature and normal humidity for 1 to 2 hours. The change of $V_{1\text{mA}}$ shall be measured.  在温度为 $40\pm 2^{\circ}\text{C}$ , 湿度为 90~95%RH 中无负荷放置 1000 小时, 其后在室温状态下, 1 小时以上 2 小时以内测量 $V_{1\text{mA}}$ 。	$ \Delta V_{1\text{mA}}/V_{1\text{mA}} $ $\leq 10\%$
Low Temperature Storage 低温存储	The specimen shall be subjected to $-40\pm 2^{\circ}\text{C}$ , for 1000 hours with-out load and then stored at room temperature and normal humidity for 1 to 2 hours. The change of $V_{1\text{mA}}$ shall be measured.  在温度为 $-40\pm 2^{\circ}\text{C}$ , 无负荷放置 1000 小时其后在室温状态, 1 到 2 小时以内测量 $V_{1\text{mA}}$ 。	$ \Delta V_{1\text{mA}}/V_{1\text{mA}} $ $\leq 10\%$
Temperature Cycle 温度快速变化	The specimen shall be subjected to $-40\pm 2^{\circ}\text{C}$ , then to $125\pm 2^{\circ}\text{C}$ . At each temperature the specimen shall be stored for 30 minutes. The temperature cycle shall be applied for 5 times.  下限类别温度 $-40\pm 2^{\circ}\text{C}$ , 上限类别温度 $125\pm 2^{\circ}\text{C}$ , 共五个循环, 每个极限温度下放置 30 分钟, 进行外观检查和 $V_{1\text{mA}}$ 测量。	No remarkable mechanical damage $ \Delta V_{1\text{mA}}/V_{1\text{mA}} $ $\leq 10\%$ 无可见损伤
High Temperature Load 高温负荷	After being continuously applied the max. allowable voltage at $125\pm 2^{\circ}\text{C}$ for 1000 hours and then stored at room temperature and normal humidity for 1 to 2hours. Thereafter, the change of $V_{1\text{mA}}$ shall be measured.  在 $125\pm 2^{\circ}\text{C}$ 的温度下, 施加最大连续电压 1000 小时; 然后, 在室温状态下, 1 到 2 小时以内进行 $V_{1\text{mA}}$ 测量。	$ \Delta V_{1\text{mA}}/V_{1\text{mA}} $ $\leq 10\%$
Humidity Load 湿热负荷	The specimen shall be subjected to $40\pm 2^{\circ}\text{C}$ , 90~95%RH and the max. allow able voltage for 1000 hours and then stored at room temperature and normal humidity for 1to 2hours. Thereafter, the change of $V_{1\text{mA}}$ shall be measured.  在温度为 $40\pm 2^{\circ}\text{C}$ , 湿度为 90~95%RH 中, 施加最大连续电压 1000 小时, 其后在室温状态下, 1 到 2 小时以内测量 $V_{1\text{mA}}$ 。	$ \Delta V_{1\text{mA}}/V_{1\text{mA}} $ $\leq 10\%$

Part No: HYV6355 series

Rev: 1/A (2024-04-24)

**6. Features 特点**

- Improved component design in a compact case. 改善产品的设计空间
- High surge current capability. 提供更高的产品通流量
- Superior performance at high temperature. 在更高温下使用
- Better stability and reliability under hot and humid conditions  
在湿热条件下有更好的稳定性和可靠性
- SMD mountable disk varistors, suitable for lead-free reflow / wave soldering.  
片式封装结构更适合回流焊和波峰焊

**7. Applications 应用领域**

- Power supplies for telecommunication systems. 通讯设备功率电源
- Protection for LED circuits. LED 电路保护
- Protection for consumer, industrial equipment. 消费类、工业类设备保护
- Protection for automotive electronics. 自动化设备保护

**8. Applicable standards 参照标准**

- UL1449
- TUV
- CQC (GB/T10193, GB/T10194, GB4943.1, GB8898)

**9. General technical data 技术要求**

Parameter 项目	Value 范围	Unit 单位
Operating temperature 工作温度	-10 to +125	°C
Storage temperature 贮存温度	-10 to +45	°C
Electric strength 电气强度	≥2.5	kV <sub>RMS</sub>
Insulation resistance 绝缘电阻	≥100	MΩ

**10. Storage condition 贮存条件**

- As far as possible, the components should be employed within 24 months after delivery .  
从入库到使用时间不大于 24 个月。
- They should be left in their original packing to avoid soldering problems due to oxidized contacts. 为防止出现焊接问题产品尽量在使用前保持原包装。
- Storage temperature: - 10 up to + 45° C. 贮存温度在-10~45° C.
- Relative humidity: < 75 % 相对湿度 <75%。



